

## LOXrail® 40 fixing clamp

Art. No. 480202

Drawing No. 80000-0016



- └ Fixing clamp for LOXrail 25/40 for fixing the floor rail on steel beams or flat steel
- └ Adjustment option for precise setting of track center width
- └ Fixing clamps will be set every 300mm on both sides of the rail
- └ We also provide ready-to-use support profiles for a floor mounted installation including a suitable hole pattern

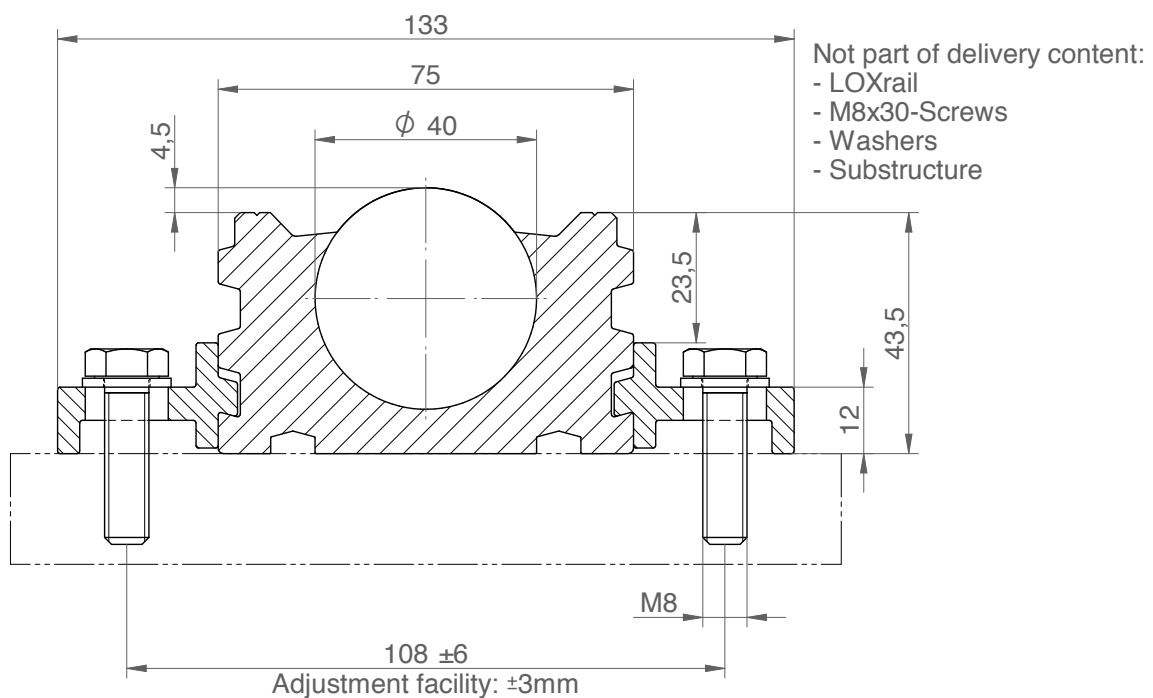

Technical data are subject to changes and errors. Only current article drawings are relevant.